

c
c
c

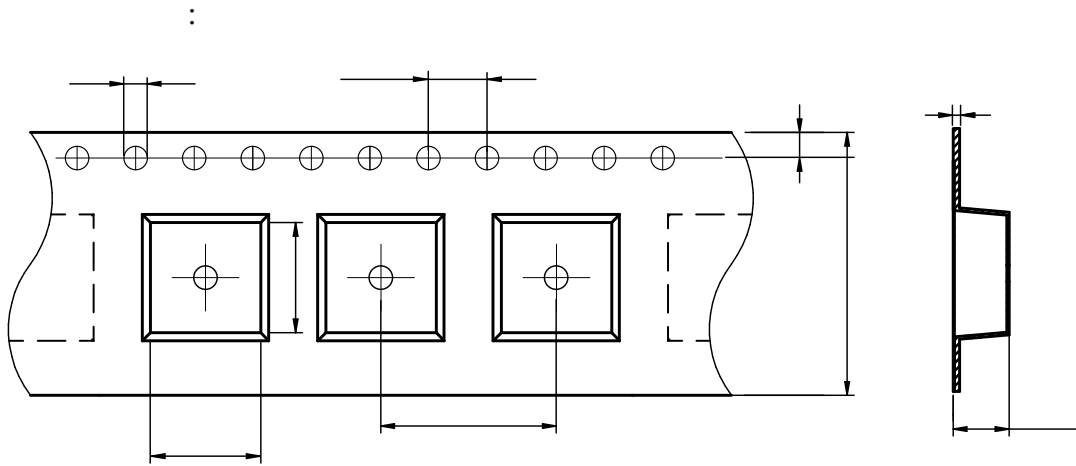

MDTA7020	8.2 ± 0.1	8.0 ± 0.1	1.5 ± 0.1	4.0 ± 0.1	12.0 ± 0.1	16.0 ± 0.3	2.3 ± 0.1	1.75 ± 0.1	0.35 ± 0.05

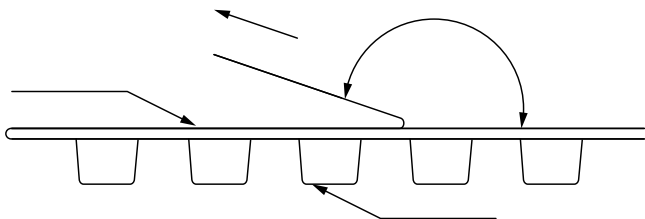

The peel force of top cover tape shall be between 0.1 to 1.3 N

Marking	Printing (Inductance)
---------	-----------------------

