

ACMA Series



FEATURES

-
-
-
-
-

APPLICATION

-

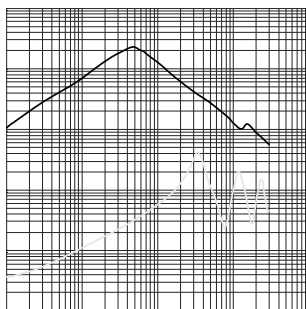
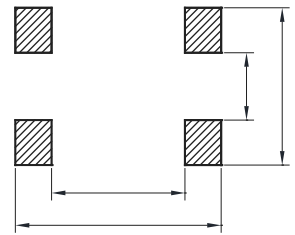
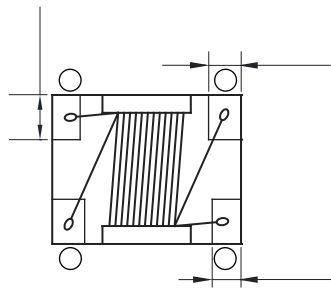
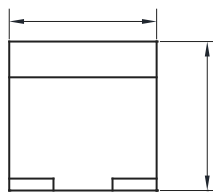
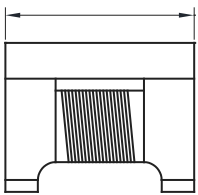

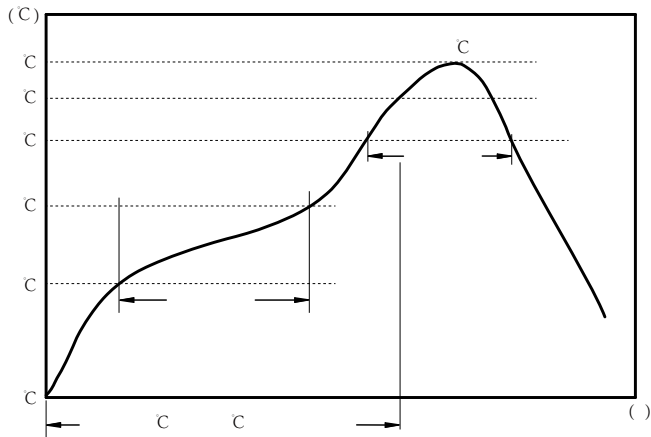

c
c
c

:

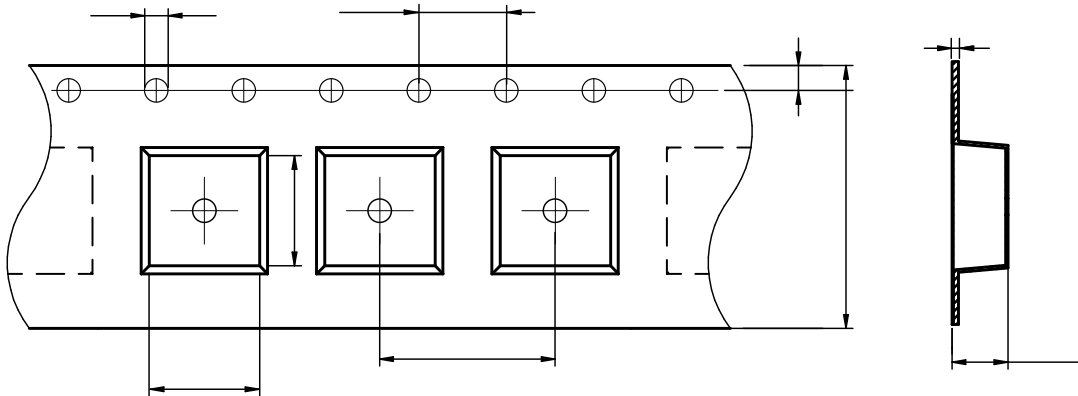

ACMA4532ETH	3.60 ± 0.1	4.90 ± 0.1	1.5 ± 0.1	4.0 ± 0.1	8.0 ± 0.1	8.0 ± 0.3	3.0 ± 0.1	1.75 ± 0.1	0.26 ± 0.05
-------------	----------------	----------------	---------------	---------------	---------------	---------------	---------------	----------------	-----------------

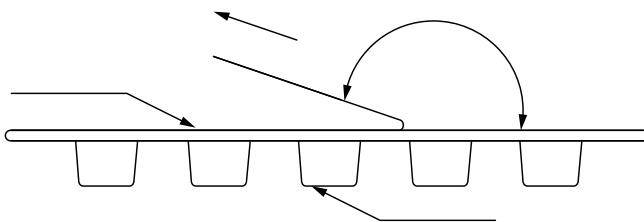

The peel force of top cover tape shall be between 0.14 to 0.78 N

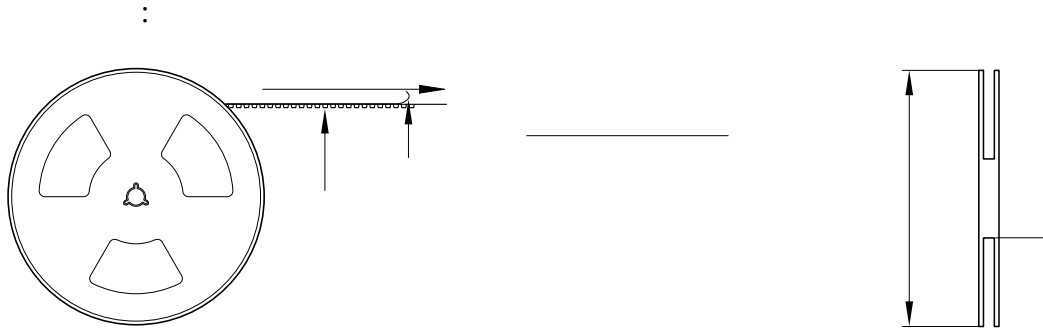

:

-
-
-
-
-
-
-
-
-